

Function Description

Remote Management

Contents

1 Introduction	1
1.1 Abbreviations and Glossary	1
2 Technical Solution	3
2.1 Virtual Ports	4
2.2 Remote Management of the RMC via for example pcAnywhere	5
3 Applications of Remote Management	6
3.1 Direct Serial Cable (RS232) Connection	6
3.2 Serial Modem Connection	7
3.3 IP Connection	8
4 Security Aspects	9
5 System Requirements	10
6 System Installation and Configuration	11
6.1 Direct Serial Cable (RS232) Connection	11
6.1.1 Physical Installation of Direct Serial Cable (RS232) Connection	11
6.1.2 Configuration of Direct Serial Cable (RS232) Connection	11
6.2 Serial Modem Connection	15
6.2.1 Physical Installation of Serial Modem Connection	15
6.2.2 Configuration of Serial Modem Connection	15
6.3 IP Connection	17
6.3.1 Physical Installation of IP Connection	17
6.3.2 Configuration of IP Connection	17
7 Related Documents	19
8 Document History	20

1 Introduction

With remote management it will be possible to remotely manage the System 900, the DECT/PWT System, the VoWiFi System, and the teleCARE M System over a direct serial connection, modem connection, or IP connection. This makes it possible to access and configure customer sites, independent of distance.

It is also possible to connect the Ascotel Mobility Interface (AMI) and the Ascotel Information Managements System (AIMS), over a modem, or by direct serial cable connection. See [6 System Installation and Configuration](#) on page 11.

The IP network connection is used when an IP connection to the site already exists, for example via VPN (Virtual Private Network). As an alternative a modem connection can be used. The direct line connection is used when working on the actual customer site.

The Remote Management Client (RMC) is used to administrate and set up the connection to customer sites. Once the connection is established, the existing tools listed below are used as usual.

- WinBK for System 900
- Cordless System Manager (CSM) for System 9d and PWT
- teleCARE M Installation Program (TIP) for teleCARE M
- Internet Explorer for web-based applications

Note: Over a modem or direct serial connection it is not possible to access the FTP area of Unite modules. This will be supported in a future release of the ESS/Unite CM.

1.1 Abbreviations and Glossary

A-bus	serial communication between modules in System 900.
CSM	Cordless System Manager: PC-based tool used to configure cordless telephone systems.
DECT	Digital Enhanced Cordless Telecommunications: global standard for cordless telephony.
ELISE	Embedded Linux SErver: hardware platform used for Unite products.
ESS	Enhanced System Services: Unite module that supports advanced message routing and centralised fault handling and logging.
IAM	Intelligent Address Module: teleCARE M module on LON that connects other teleCARE M modules and peripherals.
IMS2	Integrated Wireless Messaging and Services: Unite module that enables wireless services to and from portable devices and chargers. It also includes the Device Manager.
IP	Internet Protocol: global standard that defines how to send data from one computer to another through the Internet.
ISC	Internetworking System Controller: Unite module that enables nurse calls to be transferred from the teleCARE M system to for example System 900 or a cordless telephone system.

LAN	Local Area Network: a group of computers and associated devices that share a common communication line.
LON	Local Operating Network: platform for connection of devices, used in teleCARE M for communication.
PPP	Point-to-Point Protocol: global protocol used for IP communication between two computers using a serial interface.
PWT	Personal Wireless Telecommunication: US standard for cordless telephony.
RMC	Remote Management Client: PC tool that enables remote access to the Unite system.
SLA	Serial LON Adapter: used to connect a PC to the LON network when installing and configuring a teleCARE M system.
SMM	System Monitoring Module: supervises the modules connected to the LON network in the teleCARE M system.
System 900	generic term for telePROTECT, teleCOURIER, and CTS 900 systems.
System 9d	generic term for Ascom DECT System.
TCP	Transmission Control Protocol: standard IP protocol that enables two hosts to establish connection and exchange streams of data with guarantee of data delivery and that data packets will be delivered in the same order that they were sent.
TIP	teleCARE M Installation Program: PC tool used to install and configure the teleCARE M system.
TLM	Telephone Line Module: teleCARE M module that enables connection of analogue telephone lines.
Unite	generic term for messaging system that unites different systems, for example System 900, System 9d, and teleCARE M.
Unite CM	Unite Connectivity Manager: Unite module that enables messaging and alarm handling in a system. It also includes the Device Manager.
VoWiFi	Voice over Wireless Fidelity: wireless version of VoIP that refers to IEEE 802.11a, 802.11b, 802.11g, or 802.11n network.
VPN	Virtual Private Network: a way to use, for example, the Internet to create secure remote access.
WinBK	PC-based tools for installation and configuration of System 900.

2 Technical Solution

Remote management is enabled via a direct serial cable (RS232), serial modem connection, or an IP connection.

The ESS/Unite CM includes a point-to-point protocol (PPP) server that converts the serial interface protocol to IP and vice versa. The RMC connects to the server in the ESS/Unite CM. The communication can be linked further via another Unite module that is connected to the ESS/Unite CM.

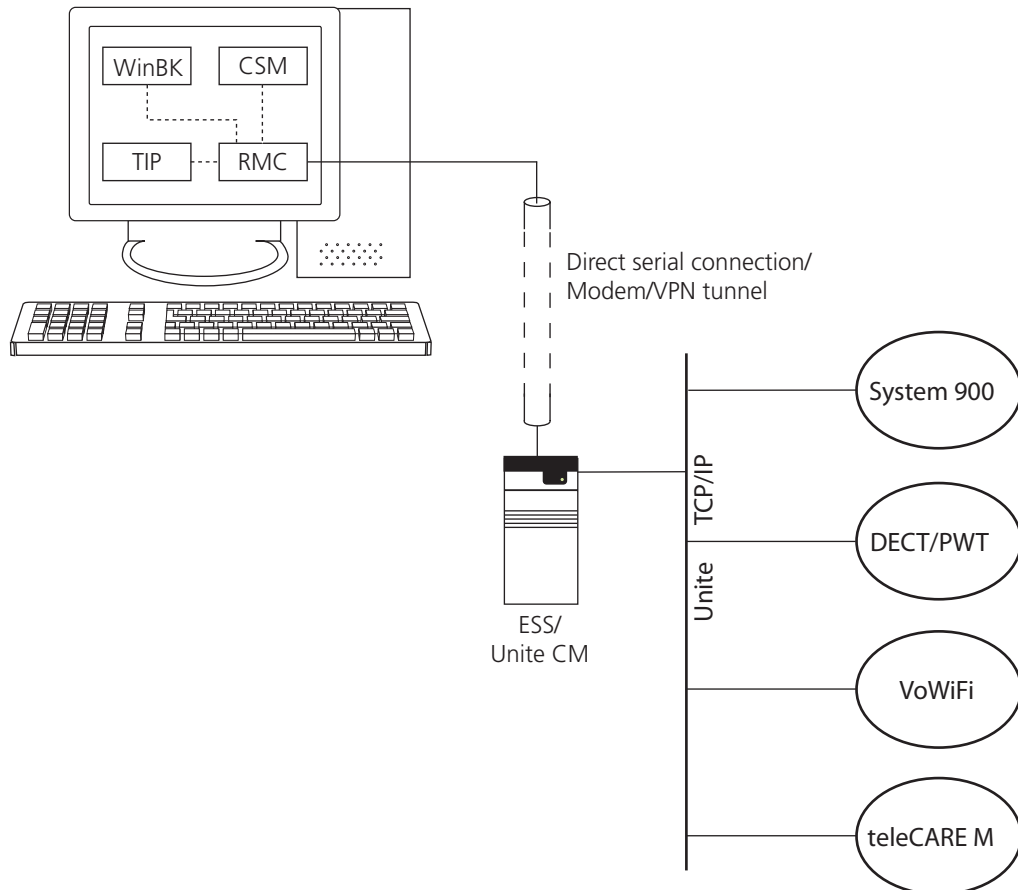

Figure 1. Remote management.

2.1 Virtual Ports

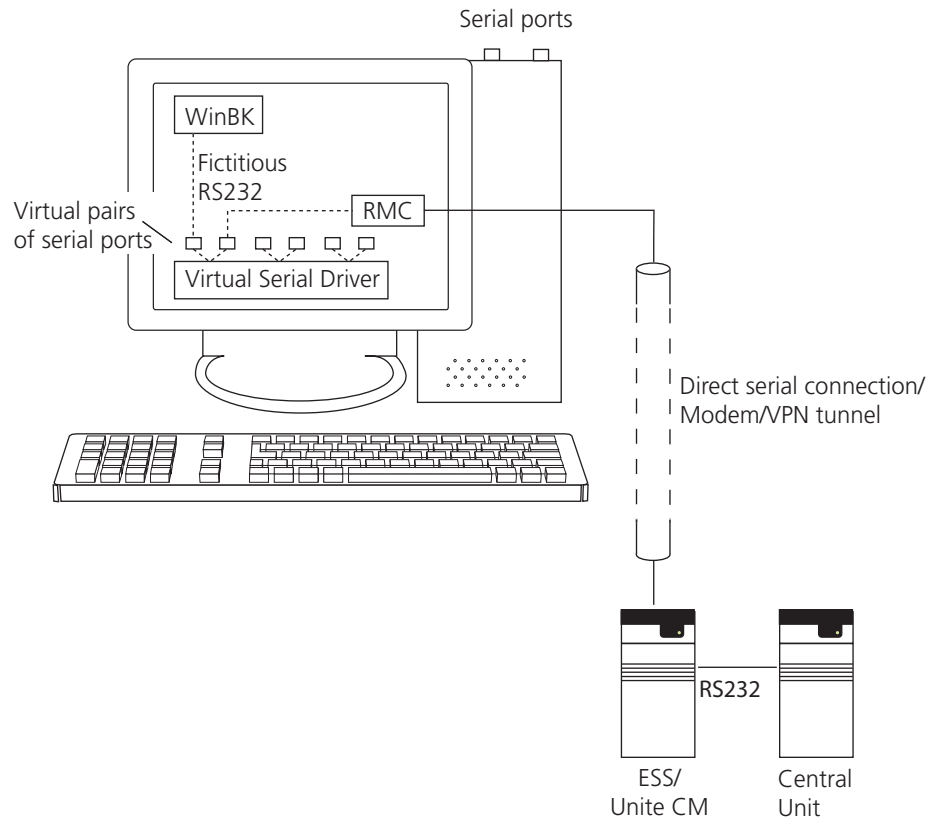

Figure 2. Virtual ports.

Instead of connecting the physical ports on the PC, virtual pairs of serial ports are created and used for the remote connection. No updates of the configuration tools (for example WinBK) are needed. The tools use one of the virtual ports and the other virtual port is connected to the RMC.

By using the virtual pairs of serial ports, more ports and any desired port number can be used. All RS232 ports of the Unite modules can be used to connect, for example, a Central Unit or Radio Exchange.

Note: There can be limitations regarding the port usage. COM1 or COM2 ports are often used for other hardware. WinBK and CSM can only use up to COM4 while TIP can use up to COM10. Be also aware about which port an internal PC modem uses as it might conflict with the virtual ports.

Virtual ports are only used for serial communication over a virtual link, that means, when using WinBK, CSM or TIP. For configuration with web-based tools, virtual ports are not needed.

As in the example in [figure 3](#), the first pair of virtual ports can be as follows:

- Port that the administration tool WinBK connects to: COM3
- Port to the RMC: COM13

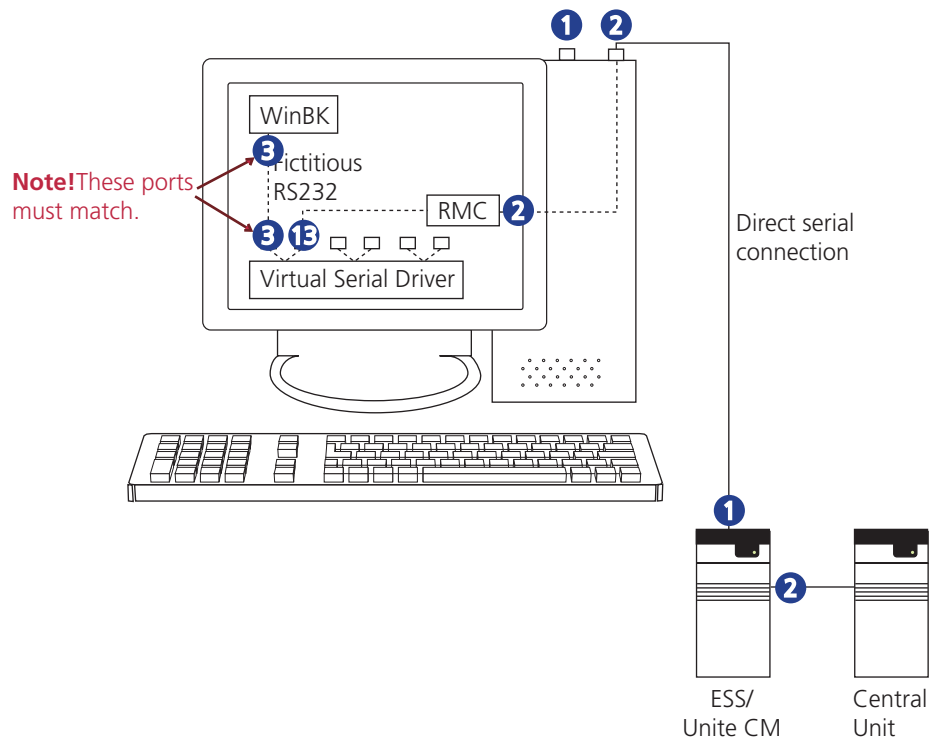

Figure 3. Example of port settings.

The internal PC port settings (virtual ports 3 and 13) are set in the RMC. The outgoing PC port setting (interconnected port 2) is set in the RMC settings for the direct line connection, see Installation and Operation Manual, Remote Management Client, TD 92256GB.

The ESS/Unite CM ports (ports 1 and 2) are configured in the ESS/Unite CM, see [6 System Installation and Configuration](#) on page 11.

2.2 Remote Management of the RMC via for example pcAnywhere

pcAnywhere from Symantec is one of several computer programs that lets you access your PC from another PC via internet, LAN or phone connection. It allows you to work on your computer remotely as if you were sitting in front of it. pcAnywhere can be used to access the RMC remotely, see [figure 4](#) below.

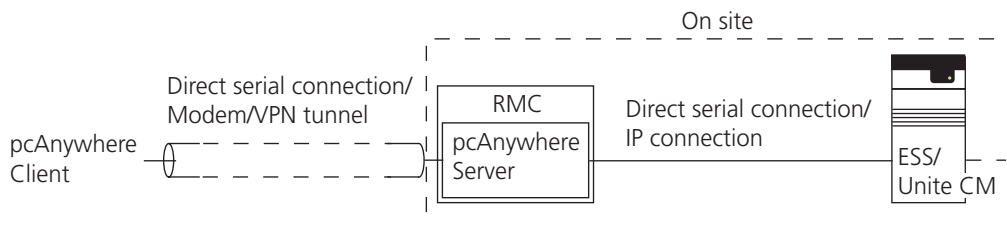

Figure 4. Remote management via pcAnywhere.

Note that it is not possible to tunnel pcAnywhere data through an ESS/Unite CM, that means, in the figure above the RMC and ESS/Unite CM cannot switch places.

3 Applications of Remote Management

There are different ways to connect to a site remotely. This chapter shows three different examples:

- Direct Serial Cable (RS232) Connection to System 900
- Serial Modem Connection to a DECT/PWT System
- IP Connection to a teleCARE M System

3.1 Direct Serial Cable (RS232) Connection

Often this direct connection is used when working on the actual customer site. In this example, the computer with the RMC is connected directly to the ESS/Unite CM at the customer site via a serial cable. The ESS/Unite CM connects to the Central Unit in System 900 via PC-line. The configuration tool for System 900 (WinBK) runs on the same computer as the RMC, see [figure 5](#) below.

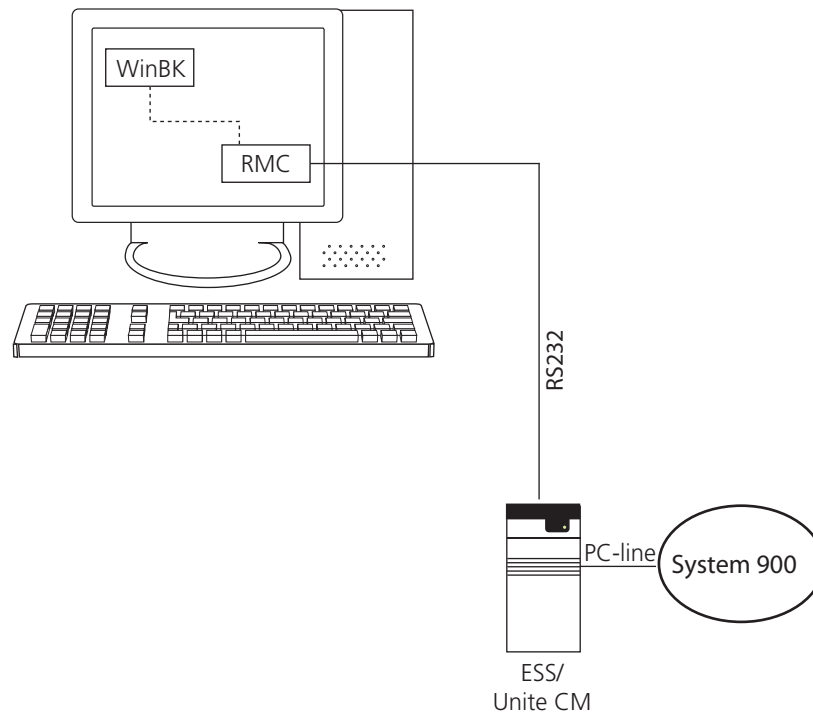

Figure 5. System 900 remotely administrated via a direct serial cable (RS232).

3.2 Serial Modem Connection

In this example, the serial connection runs over modems from the RMC to the ESS/Unite CM at the customer site. The configuration tool for System 9d (CSM) runs on the same computer as the RMC. The communication between the CSM and the Radio Exchange in the DECT/PWT System is linked via an Integrated Wireless Messaging and Services (IMS2) or a Unite CM, see [figure 6](#) below.

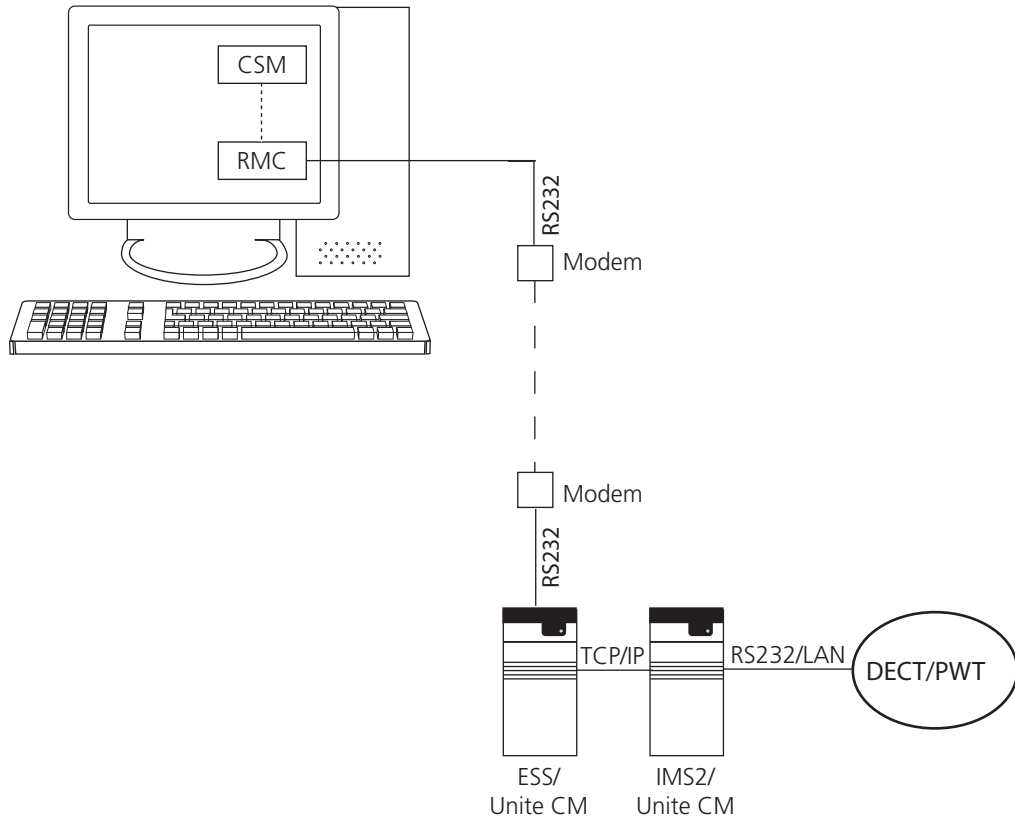

Figure 6. DECT/PWT system remotely administrated via serial modems.

3.3 IP Connection

In this example, the connection between the RMC and the ESS/Unite CM runs over a virtual private network (VPN). The configuration tool for the teleCARE M system (TIP) runs on the same computer as the RMC and is used to connect to the teleCARE M system on the customer site. The communication between TIP and the SLA in the teleCARE M system is linked via an Internetworking System Controller (ISC), see [figure 7](#) below.

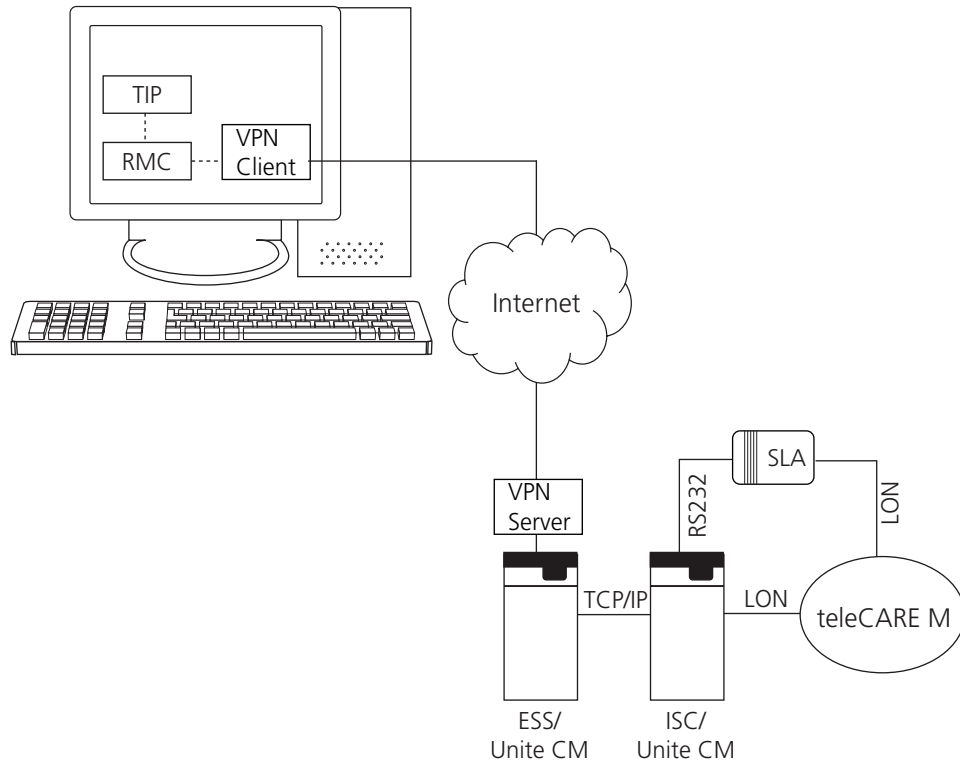

Figure 7. teleCARE M system remotely administrated via an IP connection.

4 Security Aspects

It is recommended that the security level is in accordance with related IT solutions at the customer site.

Sometimes access to the customers IP network is unavailable, because of the customers security policy/fire wall. By using one of the following security levels, it is still possible to access the customer system:

- 1 ESS/Unite CM has a built-in fire wall, which only allows TCP traffic on port 80 (web browser traffic) and on ports 10101 (tunneling traffic) and 10103 (serial port traffic). This should satisfy some customers.
- 2 If possible, let the system operate on a separate network. A Netpage or Mailgate could still be used on the customer network by letting them be connected to the A-bus instead of the Unite network. Note that these applications then cannot be managed from ESS/Unite CM.
- 3 A variant of 2) is to create a virtual network for the system. Then access can be granted (by the customer) for specific modules and protocols to access the customers network.
- 4 Use ESS/Unite CM with a modem connection. The customer can disconnect the modem and only connect it to the Unite System when required.
- 5 Combine 4) with an easy way to disconnect the Unite System from the rest of the customer network. Then the customer disconnects the Unite System from the network and allows modem connection after that. Note that some messaging functions may not be available during this period (for example Netpage).

For more information about IT security, see also System Planning Unite, TD 92258GB.

5 System Requirements

Cables

Direct line between PC (RMC) and ESS/ Unite CM:	541479 Elise RS232 Cable.
PC (RMC) to its modem:	Modem cable working with the PC modem.
ESS/Unite CM to its modem:	- Twisted pair network cable. - 180714 Adapter D25F-8/8 Modem-T942C.
ESS/Unite CM to the Central Unit:	- Two twisted pair network cables. One attached to the RS232 connector on the ESS/Unite CM and the other to the RJ45 socket on the Central Unit. - 541480 Elise RJ45 Cable adapter. Conductor joint which turns the cables the right way.
ISC to the SLA (Serial LON Adapter):	541479 Elise RS232 Cable.

Modems

Connected to the PC (RMC):	Any Windows-compatible modem.
Connected to the ESS/Unite CM:	Requires understanding of the following commands from the ESS/Unite CM: - ATE1 to turn "Echo ON" - ATSO=1 activation for "Auto answer".

Software

ESS:	ESS version 1.03 or later ^a
Unite CM:	Unite CM version 1.00 or later
IMS2:	IMS2 version 2.62 or later
ISC:	ISC version 3.01 or later

a. Some settings in this document has functionality that require a later version. See respective chapter for later software version.

For cable configurations, see Installation and Operation Manual, Remote Management Client, TD 92256GB.

6 System Installation and Configuration

The installation and configuration is depending on which type of connection that is used, direct serial cable, modem or IP connection. This chapter will follow the examples described in [3 Applications of Remote Management](#) on page 6.

The installation of the Remote Management Client (RMC) is described in Installation and Operation Manual, Remote Management Client, TD 92256GB.

6.1 Direct Serial Cable (RS232) Connection

6.1.1 Physical Installation of Direct Serial Cable (RS232) Connection

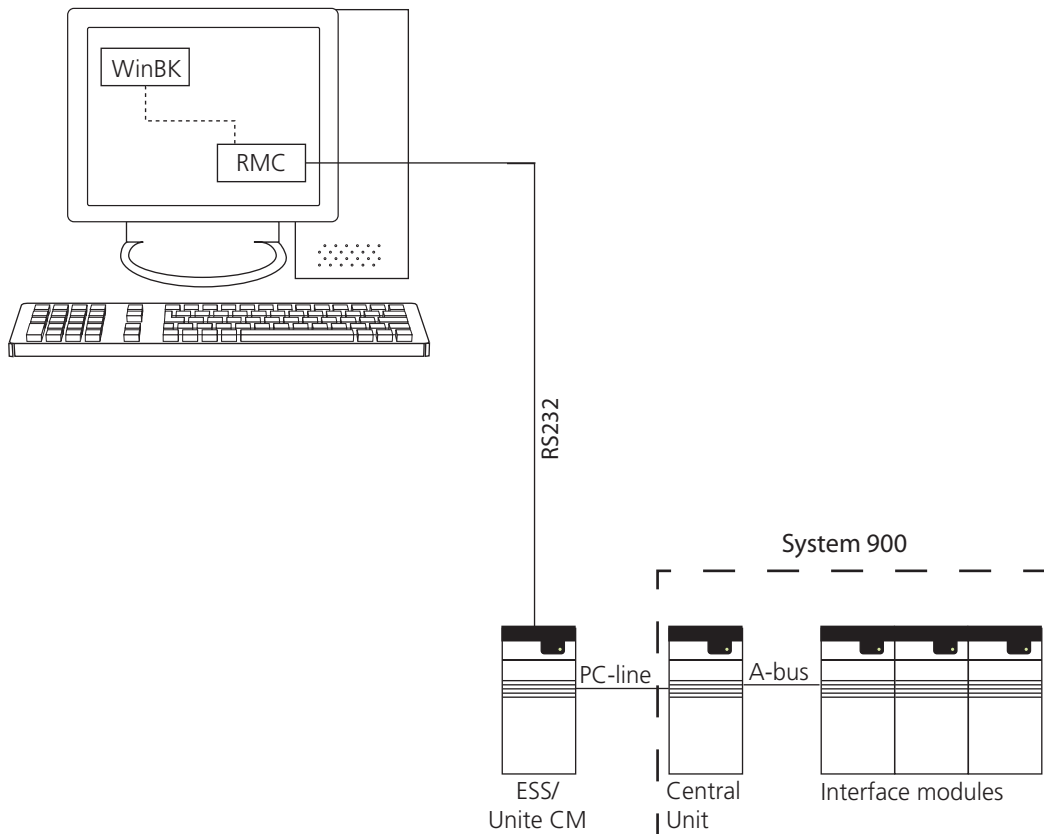

Figure 8. Direct serial cable (RS232) connection to System 900.

6.1.2 Configuration of Direct Serial Cable (RS232) Connection

- 1 Open the ESS/Unite CM configuration page by writing the IP address of the ESS/Unite CM in the web browser address field, followed by "/admin", i.e. `http://xxx.xxx.xxx.xxx/admin`. Log on with the user name "admin". The default password is "changeme".
- 2 Click "Remote Management" to open the "Remote Management Server" window, see [figure 9](#) below.
In "Remote connection" it is possible to edit the remote configuration settings, and the "Serial port channel", that tunnels a transparent channel to, for example, System 900. It is also possible to open ports for forwarding, for connection of the Remote Management Client.

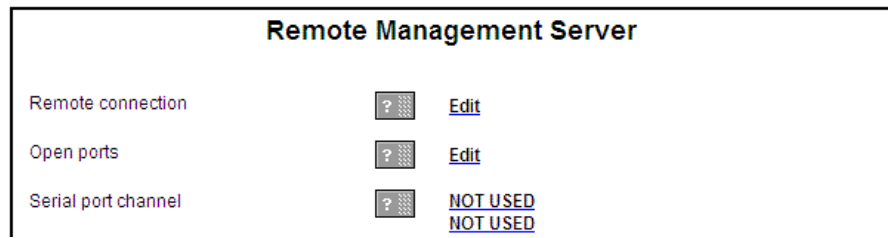

Figure 9. Main page of the Remote Management Server.

- 3 On the "Remote connection" row, click "Edit" to enter the "Connection parameters" window. With direct line connection, the following fields have to be set up, see figure 10 and table below.

Field	Configuration
Password	If used, state the password to establish a remote connection.
Require user identification	Choose "Yes", if user identification is required, or "No" when requirement is not needed. When using an ESS, this function requires ESS 2.00 and RMC 2.00.
Serial port	Choose the serial port of the ESS/Unite CM that connects to the RMC.
PPP server address	State a second IP address of the ESS/Unite CM to be used for PPP. Provided by the IT responsible on the customer site.
PPP client address	State a second IP address of the PC (RMC) to be used for PPP. Provided by the IT responsible on the customer site.

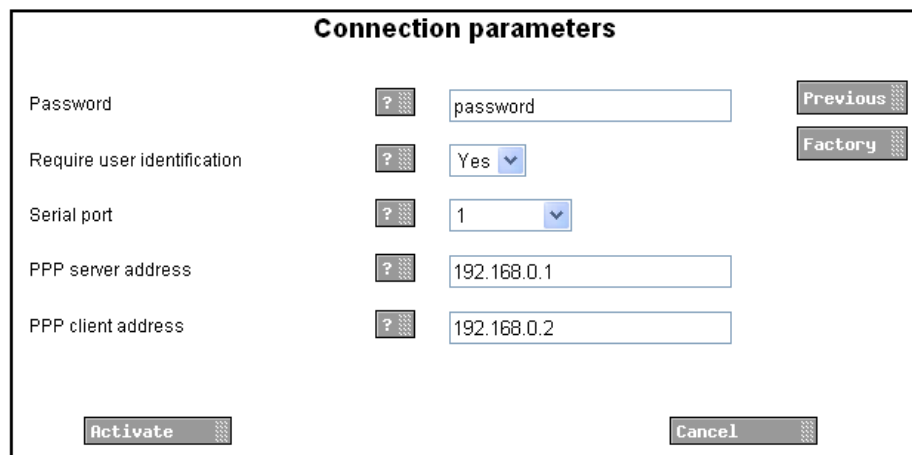

Figure 10. Settings in the Remote Management Server.

- 4 On the "Open ports" row, click "Edit" to open ports for forwarding, see table below and [figure 12](#) on page 14. When using an ESS, this requires ESS 2.00 or later.

Field	Configuration
Switch no. 8 must be set to be able to change parameters ^a	This is done on the hardware, where SW3:8 is set to ON. For location of the switch, see Installation Guide ELISE2, TD 92232GB.
To be able to change this setting the Confirmation Mode on the module must be set ^b	This is done on the hardware by pushing the "Mode" button when it is blinking. For location of the button, see Installation Guide ELISE3, TD 92679GB
Open ports	Ports higher than 1024 can be opened for forwarding.

a.ELISE2
b.ELISE3

Figure 11. Settings for connection of the Remote Management Client.

Note: To be able to change/save the parameters, SW3:8 on the hardware must be set to ON (ELISE2), or the Confirmation Mode on the module must be set (ELISE3).

- 5 In this example, the Central Unit is connected to the ESS/Unite CM. Select the first "NOT USED" serial port channel, see [figure 9](#). The communication to the Central Unit can be set up as in [figure 12](#).

Field	Configuration
Name	State the name of the channel which is to be shown in the RMC.
IP address	State the IP address of the ESS/Unite CM. (127.0.0.1 can be used).
Remote serial port	State the ESS/Unite CM serial port where the Central Unit is connected.
Baud rate	State the baud rate of the communication. It must correspond to the setting in the Central Unit (normally 9600).
Parity	State the parity of the communication. It must correspond to the setting in the Central Unit (normally Even).
Notes	Free text field for more information about this connection.

Serial port channel

Name	?	<input type="text" value="WinBK"/>	<input type="button" value="Previous"/>
IP address	?	<input type="text" value="127.0.0.1"/>	<input type="button" value="Factory"/>
Remote Serial port	?	<input type="text" value="2"/>	
Baud rate	?	<input type="text" value="9600"/>	
Parity	?	<input type="text" value="Even"/>	
Notes	?	<input type="text"/>	

Figure 12. Remote Management via ESS/Unite CM to Central Unit in System 900.

6.2 Serial Modem Connection

6.2.1 Physical Installation of Serial Modem Connection

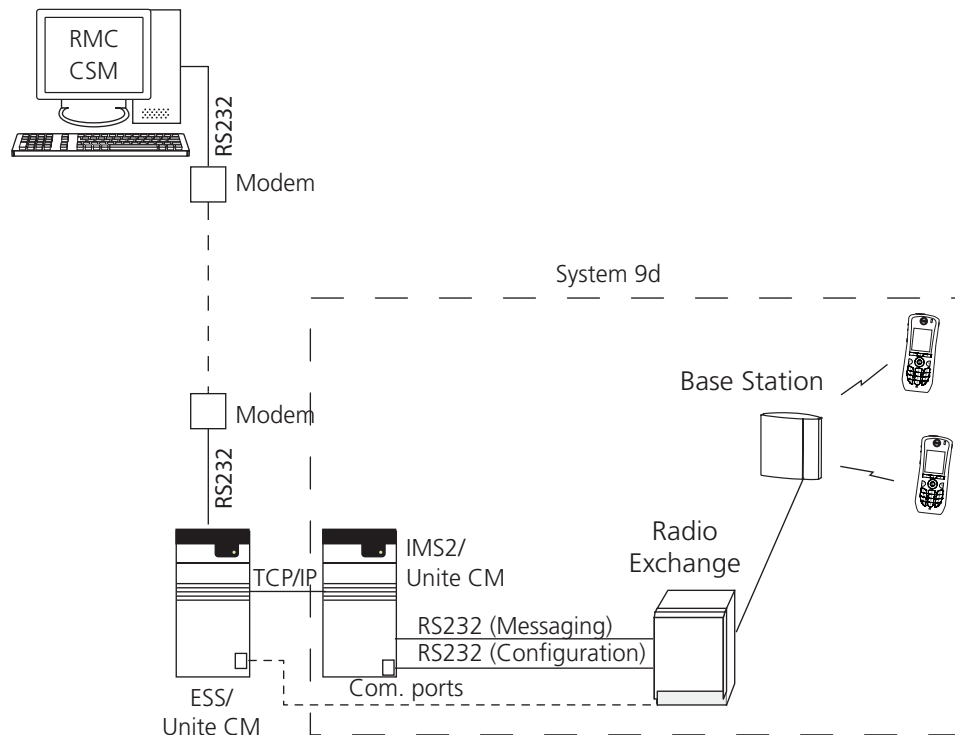

Figure 13. Serial modem connection to a DECT System.

On the IMS2/Unite CM two communication ports are used, one for messaging and one for the configuration. Normally the IMS2/Unite CM and Radio Exchange are placed close to each other as there is a physical connection. If, however, the IMS2/Unite CM and Radio Exchange are placed far from each other and a separate ESS is used, it is possible to connect the RS232 communication for configuration directly from the ESS to the Radio Exchange, instead of using the IMS2/Unite CM for that purpose (dotted line in [figure 13](#) above.)

6.2.2 Configuration of Serial Modem Connection

- 1 Open the ESS/Unite CM configuration page by writing the IP address of the ESS/Unite CM in the web browser address field, followed by "/admin", i.e. `http://xxx.xxx.xxx.xxx/admin`. Log on with the user name "admin". The default password is "changeme".
- 2 Click "Remote Management" to open the "Remote Management Server" window, see [figure 9](#) on page 12.
- 3 On the "Remote connection" row, click "Edit" to enter the "Connection parameters window. With modem connection, the following fields have to be set up, see table below and [figure 10](#) on page 12.

Field	Configuration
Password	State the password to establish a remote connection.
Serial port	Choose the serial port of the ESS/Unite CM that connects to the RMC.
PPP server address	State a second IP address of the ESS/Unite CM to be used for PPP.
PPP client address	State a second IP address of the PC (RMC) to be used for PPP.

- 4 On the "Open ports" row, click "Edit" to open ports for forwarding, see the table below and [figure 12](#) on page 14 When using an ESS, this requires ESS 2.00 or later.

Field	Configuration
Switch no. 8 must be set to be able to change parameters ^a	This is done on the hardware, where SW3:8 is set to ON. For location of the switch, see Installation Guide ELISE2, TD 92232GB.
To be able to change this setting the Confirmation Mode on the module must be set ^b	This is done on the hardware by pushing the "Mode" button when it is blinking. For location of the button, see Installation Guide ELISE3, TD 92679GB
Open ports	Ports higher than 1024 can be opened for forwarding.

a.ELISE2
b.ELISE3

- 5 In this example, the communication is linked further to System 9d via an IMS2/Unite CM that is connected to the ESS/Unite CM. Select the first "NOT USED" serial port channel, see [figure 9](#) on page 12. The communication to the IMS2/Unite CM can be set up as in [figure 14](#).

Field	Configuration
Name	State the name of the channel which is to be shown in the RMC.
IP address	State the IP address of the IMS2/Unite CM ^a .
Remote serial port	State the IMS2/Unite CM serial port where the Radio Exchange (Configuration) is connected.
Baud rate	State the baud rate of the communication. Must correspond to the setting in the Radio Exchange (Normally 9600).
Parity	State the parity of the communication. Must correspond to the setting in the Radio Exchange (Normally None).
Notes	If desired, state more information about this connection.

a.127.0.0.1 if the same Unite CM is used both as ESS and IMS2.

Note: No settings are needed in the IMS2/Unite CM if a separate ESS is used.

Figure 14. Remote Management via ESS/Unite CM to IMS2/Unite CM in System 9d.

6.3 IP Connection

6.3.1 Physical Installation of IP Connection

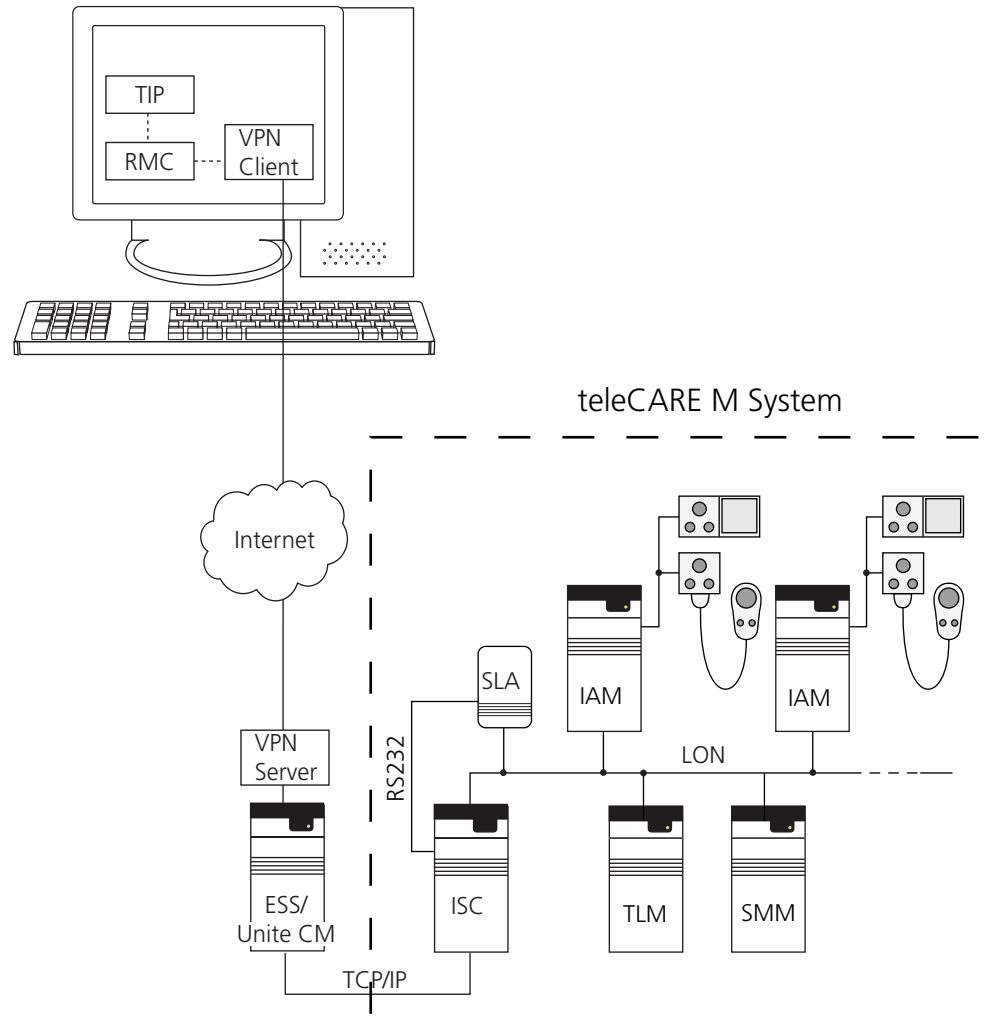

Figure 15. IP connection to a teleCARE M System.

A VPN Client must be installed on the PC according to the customer requirements regarding VPN.

6.3.2 Configuration of IP Connection

- 1 Open the ESS/Unite CM configuration page by writing the IP address of the ESS/Unite CM in the web browser address field, followed by "/admin", i.e. `http://xxx.xxx.xxx.xxx/admin`. Log on with user name "admin". The default password is "changeme".
- 2 Click "Remote Management" to open the "Remote Management Server" window, see [figure 9](#) on page 12.
- 3 On the "Remote connection" row, click "Edit" to enter the "Connection parameters window. With IP connection, only the password to establish a remote connection has to be set up, see [figure 10](#) on page 12.
Note, that by setting "Serial port" to "None" no ports are unnecessarily occupied.

- 4 In this example, the communication is linked further to the teleCARE M system via an ISC that is connected to the ESS/Unite CM. Select the first "NOT USED" serial port channel, see [figure 9](#) on page 12. The communication to the ISC can be set up as [figure 16](#).

Field	Configuration
Name	State the name of the channel which is to be shown in the RMC.
IP address	State the IP address of the ISC.
Remote serial port	State the ISC serial port where the SLA is connected.
Baud rate	State the baud rate of the communication. Must correspond to the setting in the SLA.
Parity	State the parity of the communication. Must correspond to the setting in the SLA.
Notes	If desired, state more information about this connection.

Note: No settings are needed in the ISC.

Serial port channel

Name	?	<input type="text" value="TIP"/>	<input type="button" value="Previous"/>
IP address	?	<input type="text" value="xxx.xxx.xxx.xxx"/>	<input type="button" value="Factory"/>
Remote Serial port	?	<input type="text" value="3"/>	
Baud rate	?	<input type="text" value="19200"/>	
Parity	?	<input type="text" value="None"/>	
Notes	?	<input type="text"/>	

Figure 16. Remote Management via ESS/Unite CM to ISC in teleCARE M System.

7 Related Documents

Installation Guide, ELISE2	TD 92232GB
Installation Guide, ELISE3	TD 92679GB
Installation and Operation Manual, Remote Management Client (RMC)	TD 92256GB
System Description, Unite	TD 92243GB
System Planning, Unite	TD 92258GB
Data Sheet, Enhanced System Services (ESS)	TD 92250GB
Installation and Operation Manual, Enhanced System Services (ESS)	TD 92253GB
Data Sheet, Unite CM (ELISE2)	TD 92719GB
Installation and Operation Manual, Unite CM (ELISE2)	TD 92718GB
Data Sheet, Unite CM (ELISE3)	TD 92739GB
Installation and Operation Manual, Unite CM (ELISE3)	TD 92735GB
User Guide, WinBK version 5.0	TD 91592GB
Setup & Application, teleCARE M Nurse Call System	TD 91791GB

8 Document History

Version	Date	Description
A	21 September 2004	First version.
B	24 January 2006	Updated version.
C	22 December 2010	<ul style="list-style-type: none">• Replaced IMS/IP-WiFi with IMS2 throughout.• Added Unite CM throughout.• Added VoWiFi throughout.• Added Unite CM IP address in chapter 6.1.2 Configuration of Direct Serial Cable (RS232) Connection on page 11.• Added "Mode" button on ELISE3 hardware in chapters 6.1.2 Configuration of Direct Serial Cable (RS232) Connection on page 11, and 6.2.2 Configuration of Serial Modem Connection on page 15.