

# **Installation and Operation Manual**

## **USI – Unite Serial Interface**

## Contents

<b>1 Introduction</b> .....	<b>1</b>
1.1 About this Manual .....	1
1.2 Abbreviation and Glossary .....	1
1.3 Technical Solution .....	2
1.4 Requirements .....	2
<b>2 Installation (ELISE2)</b> .....	<b>3</b>
2.1 Connections .....	3
2.2 RS232 Communication with External Equipment .....	4
2.2.1 Cables for the ESPA-, the Ascom Line-, and the TAP protocol .....	4
2.3 RS422 Communication with External Equipment .....	5
<b>3 Configuration</b> .....	<b>6</b>
3.1 Serial Protocol Settings .....	6
3.1.1 ESPA Protocol .....	6
3.1.2 Ascom Line Protocol .....	8
3.1.3 TAP Protocol .....	9
<b>4 Related Document</b> .....	<b>11</b>
<b>5 Document History</b> .....	<b>11</b>
<b>Appendix A: Protocol Limitations</b> .....	<b>12</b>
A.1 ESPA 4.4.4 .....	12
A.2 Limitations in the Ascom Line Protocol .....	13
A.3 TAP Protocol .....	14

## 1 Introduction

Unite Serial Interface (USI) is a product that enables text messaging from external equipment. USI is a Unite module based on the ELISE2 hardware and can be connected to System 900 or work in combination with other Unite modules.

USI includes three serial interfaces for physical connection to external equipment and one System 900 interface for connection to the A-bus in System 900. This enables the possibility to receive pagings from external equipment and send them to portable devices in System 900.

The serial interface supports the ESPA 4.4.4 protocol and two ESPA dialects; the Ascom dialect (teleCOURIER) and Ericsson dialect with some limitations, refer to [Appendix A](#). The serial interface also supports the TAP 1.8 protocol and a simplified protocol called the Ascom Line protocol.

The Ascom Line protocol is designed to be simple enough to be controlled manually, using a terminal program connected to the serial port.

A detailed description of the two ESPA dialects and the Ascom Line protocol can be found in the document; *Protocol Serial Data Interface S942SI, TD 92088GB*.

TAP (Telocator Alphanumeric Protocol) is a paging protocol used to transmit up to a thousand 7-bit characters to an alphanumeric pager. Developed in the early 1980s by the Telocator Paging Association, which later became the Personal Communications Industry Association (PCIA), TAP was also known as IXO and PET. TAP is widely used in the U.S. and throughout Europe.

### 1.1 About this Manual

This manual is a complement to the *Installation Guide, ELISE2, TD 92232GB* and contains USI related information only. The manual is aimed for the installation and configuration of the USI.

Knowledge of the system environment and the protocol used is assumed. Limitations in the protocols are described in [Appendix A: Protocol Limitations](#) on page 12.

### 1.2 Abbreviation and Glossary

A-bus	Serial communication between modules in System 900
ESPA 4.4.4	A message-based serial protocol intended for communication with external equipment. Built upon the ISO1745 transport specification.
LAN	Local Area Network: a group of computers and associated devices that share a common communication line.
Ascom Line protocol	A simple alternative to ESPA 4.4.4 with all basic features of paging call available but with a very limited status report.
System 900	Generic term for telePROTECT900, teleCOURIER 900, and CTS 900 systems.
System 9d	Ascom DECT System
TAP	Telocator Alphanumeric Protocol: An industry standard protocol for the input of paging request.
teleCARE M	Nurse Call System, built on a local operated network (LON)

teleCOURIER 900	Ascom On Site Paging System
telePROTECT 900	Ascom Personal Security System
Unite	Name of the Ascom IP based system for handling, events, messages and alarms.

### Licences

- Variants
  - USI-M1: USI including ELISE2 and USI-L1
  - USI-L1: Licence for USI

## 1.3 Technical Solution

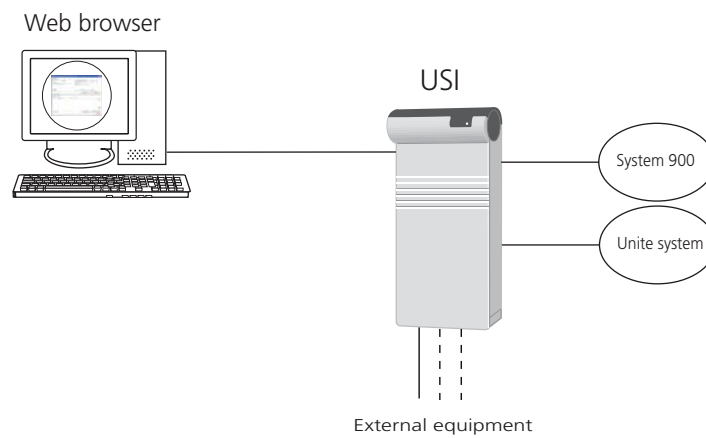

Figure 1. Solution overview

The USI can receive pagings from connected external equipment, provided the equipment supports ESPA 4.4.4, the Ascom Line protocol or the TAP protocol. USI can send the received pagings to connected System 900 or to other Unite modules. The USI can receive pagings simultaneously from three external equipment.

Cables for the connections are found in [2.2.1 Cables for the ESPA-, the Ascom Line-, and the TAP protocol](#) on page 4.

## 1.4 Requirements

Refer to the *Data Sheet USI – Unite Serial Interface, TD 92564GB*.

## 2 Installation (ELISE2)

This chapter is a complement only. Mounting, function LED indications, how to access the USI etc. are described in the *Installation Guide, ELISE2, TD 92232GB*.

### 2.1 Connections

The placement of the connectors used for the USI is shown in [figure 2](#) below.

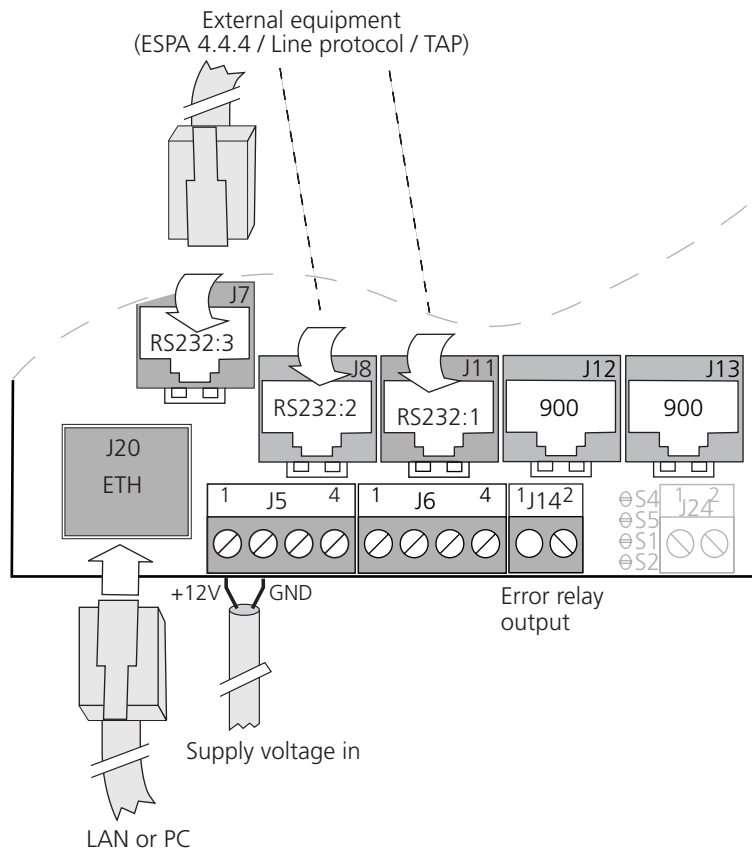

Figure 2. Connections used in USI

Connector	Description
J5	Connection of supply voltage
J6	For connection of RS422 communication. Can be used instead of RS232:2.
J7	Modular jack (RJ45) for connection of RS232 communication. RS232:3
J8	Modular jack (RJ45) for connection of RS232 communication. RS232:2
J11	Modular jack (RJ45) for connection of RS232 communication. RS232:1
J12, J13	Modular jacks (RJ45) for connection of System 900 bus cabling
J14	Connector where an error relay output is available
J20	Connection of 10baseT or 100baseT Ethernet TCP/IP network



- Before inserting cables break off suitable sections, refer to the *Installation Guide, ELISE2, TD 92232GB*.

- Use correct cable for connection to J20:
  - cross-over cable if connected directly to a PC
  - ordinary cable (straight through pinouts) if connected to the LAN
- For connections to the error relay, System 900 and to other unite modules, refer to the *Installation Guide, ELISE2, TD 92232GB*.

## 2.2 RS232 Communication with External Equipment

The USI has three identical RS232 connectors; J7, J8 and J11. The RS232 connectors on the USI is described in figure 3 below.

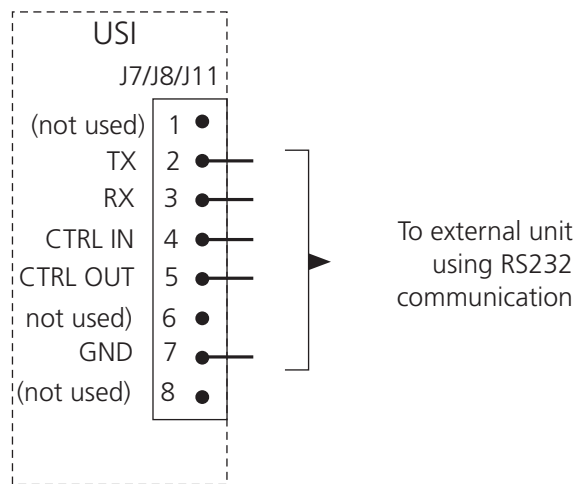

003

Figure 3. RS232 connectors

### 2.2.1 Cables for the ESPA-, the Ascom Line-, and the TAP protocol



009

Figure 4. Connection to external equipment

A cable with RJ45 and D-SUB connectors is required to be able to receive pagings from external equipment.

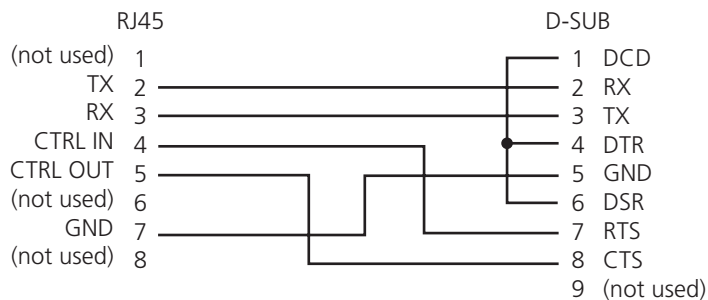

010

Figure 5. Cable wiring for the Ascom Line-, the ESPA-, and the TAP protocol

### 2.3 RS422 Communication with External Equipment

The RS422 port is connected in parallel with connector J7 (RS232:2) which means that J6 is used instead of J7. Connector J6 is connected to the external equipment as shown in the figure below.

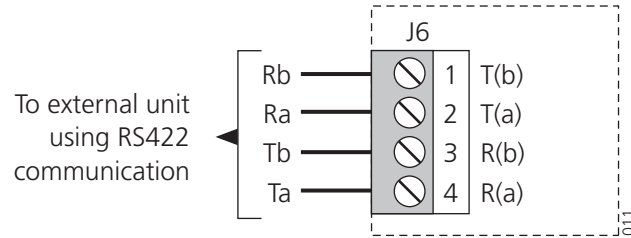

Figure 6. Connection of external equipment via the RS422 port.

### 3 Configuration

This chapter covers the parameters that can be altered on the Serial Interface pages.

#### 3.1 Serial Protocol Settings

- 1 Enter the address to the pages (xxx.xxx.xxx.xxx/admin).
- 2 Enter User ID and password. The user is called "admin" and the default password is "changeme".  
 The *Serial Interface* configuration page opens.

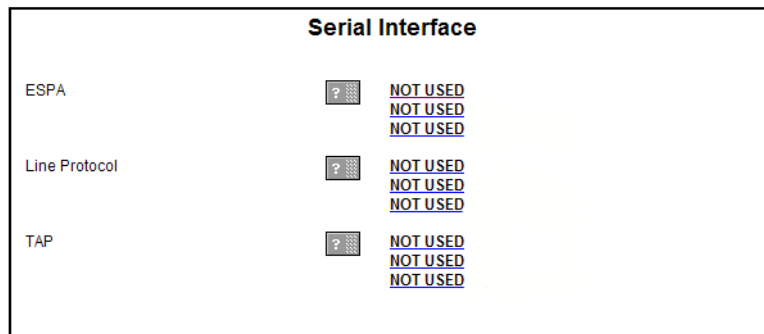

- 3 Click on an interface link for the protocol you want to use (ESPA, Line protocol or TAP).
- 4 Continue in [3.1.1 ESPA Protocol](#), [3.1.2 Ascom Line Protocol](#) on page 8 or [3.1.3 TAP Protocol](#) on page 9.

##### 3.1.1 ESPA Protocol

- 1 The following settings can be selected/changed:

<b>Settings</b>	<b>Description</b>
Enabled:	Yes/No selection. Default: No
Name:	Description of the channel
Serial port:	Port selection (1,2,3) Default: None
Bit rate:	Select bit rate. Default: 9600 bits/s.
Mode:	Select mode. Default: 8 Data bits, Even parity
Flow control:	Used for handshaking control. Default: None
ESPA dialect:	Select dialect, with or without an extra Carriage Return (CR). Default: TeleCourier extensions (i.e. Ascom dialect)
Control station selection:	Determines which module shall act as control station. Default: External equipment.
Address of external equipment:	Enter address (0 - 9). Default: 1
Address of this module:	Enter address (0 - 9). Default: 2
Default Call ID:	Number to call if not specified in the external equipment. Default: 000
Default display message:	Message to display if not specified in the external equipment. Default: BLANK

Default message priority:	Priority if not specified in the external equipment. Default: 7 (Normal)
Default beep code:	Beep code if not specified in the external equipment. Default: 2 beeps.
Default method for ack.:	Select how the paging shall be acknowledged if not specified by the external equipment. Default: No Ack.
Default urgency:	Urgency if not specified in the external equipment. Default: Normal.
Transmission delay (x10 ms):	How long to wait before transmission to external equipment. Default: 30 milliseconds
Identical pagings treatment:	How to handle identical pagings. Default: Not accepted.
Running no. to external equipment:	If running number shall be sent or not. Default: No
Timeout mode:	Determines when to start timeout mode i.e. remove paging from queue. Default: after "Call Terminated" call status.
Timeout mode TTL (seconds):	Determines the time for timeout mode i.e. during this time the paging remains in the queue after the "Timeout mode" has started. Default: 5 seconds.
Manual Ack type:	Dependent on if the external equipment supports negative acknowledge. Default: Positive and Negative manual acknowledge.
Manual Ack TTL (minutes):	How long a paging with manual acknowledge remains in the queue after transmission of <i>Call Terminated call status</i> . Default: 5 minutes.
Message Ref. ID TTL (minutes):	How long a Message Reference ID remains in queue. Only valid for Ascom dialect. Default: 5 minutes.
Interactive Message Option Text for Callback number:	Defines text that will be added to call digits sent from external equipment. The text and the number to call, is received as an option in the receiving portable device. The call digits are dialled when the user selects the option. Max 40 characters. <b>Note:</b> Overrides <i>Message Ref. ID TTL</i> . Leave empty if data identifier 9 is used for message reference.
Return Status Information:	Defines if status information for ongoing pagings shall be sent back to external equipment. Set to "No" if external equipment have problems in handling status information. Default: Yes.

Supervision time for communication (seconds):	Defines the time before lost communication with external equipment will be considered as a fault and sent as a Status log. If set to "0" no supervision is done. Max 3600 seconds Default: 0
ASCII conversion table:	Makes it possible to convert display message characters.

- 2 Click "Activate" to save the configuration.

### 3.1.2 Ascom Line Protocol

- 1 The following settings can be selected/changed:

Settings	Description
Enabled:	Yes/No selection. Default: No
Name:	Description of the channel
Serial port:	Port selection (1,2,3) Default: None
Bit rate:	Select bit rate. Default: 9600 bits/s
Mode:	Select mode. Default: 8 Data bits, Even parity
Flow control:	Used for handshaking control. Default: None
Default Call ID:	Number to call if not specified in the external equipment. Default: 000
Default display message:	Message to display if not specified in the external equipment. Default: BLANK
Default message priority:	Priority if not specified in the external equipment. Default: 7 (Normal)
Default beep code:	Beep code if not specified in the external equipment. Default: 2 beeps
Transmission delay (x10 ms):	How long to wait before transmission to external equipment. Default: 30 milliseconds
Status to ext equipment:	If status characters ACK/NAK shall be sent on protocol level to external equipment. Default: Yes
Start character :	Start character for the message. Default: < (3C Hex)
End character:	End character for the message. Default: > (3E Hex)
Record separator character:	Record separator character for the message. Default: / (2F Hex)
ACK character:	Character for positive acknowledge of the message on protocol level. Default: A (41 Hex)

- NAK character: Character for negative acknowledge of the message on protocol level. Default: N (4E Hex)
- ASCII conversion table: Makes it possible to convert display message characters.

2 Click "Activate" to save the configuration.

### 3.1.3 TAP Protocol

1 The following settings can be selected/changed:

Settings	Description
Enabled:	Yes/No selection. Default: No
Name:	Description of the channel
Serial port:	Port selection (1,2,3) Default: None
Bit rate:	Select bit rate. Default: 9600 bits/s
Mode:	Select mode. Default: 8 Data bits, Even parity
Flow control:	Used for handshaking control. Default: None
Default Call ID:	Number to call if not specified in the external equipment. Default: 000
Default display message:	Message to display if not specified in the external equipment. Default: BLANK
Default message priority:	Priority if not specified in the external equipment. Default: 7 (Normal)
Default beep code:	Beep code if not specified in the external equipment. Default: 2 beeps
Default urgency:	If set to High "Stand-by" mode in receiver is broken through. Default: Normal.
Transmission delay (x10 ms): (Advanced)	How long to wait before transmission to receiver. Default: 30 milliseconds
Enable checksum validation: (Advanced)	Set to "No" if, for example, external equipment uses an algorithm that differ from the 7-bit value used in TAP. Default: Yes
Delay time before logontimeout occurs: (Advanced)	How long to wait before disconnecting the external equipment.. Valid values: 0-127 where 0 means 'Not enabled'. Default 8 seconds
Delay time before blocktimeout occurs: (Advanced)	How long this module shall wait before hanging up. Valid values: 0-127 where 0 means 'Not enabled'. Default 4 seconds.
Numbers of allowed times to logon: (Advanced)	How many logon attempt from external equipment shall be permitted. Valid values: 1-127. Default 3 tries.

Numbers of allowed checksumfailures: ( <i>Advanced</i> )	How many checksum failures from external equipment shall be permitted. Valid values: 1-127. Default 3 tries.
Numbers of allowed timeouts:	How many timeouts shall be permitted. Valid values: 1-127. Default 3 timeouts.
ASCII conversion table:	Makes it possible to convert display message characters.

- 2 Click "Activate".

## 4 Related Document

Data Sheet USI – Unite Serial Interface	TD 92564GB
Data Sheet, ELISE2	TD 92524GB
Installation Guide, ELISE2	TD 92232GB
Protocol Serial Data Interface S942SI	TD 92088GB

## 5 Document History

For details in the latest version, see change bars in the document.

Version	Date	Description
A	19 September 2008	First released version.
B	25 March 2009	<ul style="list-style-type: none"><li>• Changed "paging messaging" to "text messaging".</li><li>• Added new protocol, see <a href="#">3.1.3 TAP Protocol</a> on page 9.</li><li>• New parameters in the ESPA protocol.</li><li>• Added chapter <a href="#">1.1 About this Manual</a> on page 1.</li><li>• Removed information about Error relay, function LED indications, addressing on the A-bus and accessing the module, since these parts are covered by the <i>Installation Guide, ELISE2, TD 92232GB</i>.</li></ul>
C	03 March 2010	Added chapter <a href="#">2.3 RS422 Communication with External Equipment</a> on page 5

## Appendix A: Protocol Limitations

This appendix describes a number of protocol specific limitations. The serial interface included in USI is a successor to the system 900 module S942SI Serial Interface and the supported protocols are described in the document *Protocol Serial Data Interface S942SI, TD 92088GB*. To be able to fully understand the limitations it is recommended to have this document available.

### A.1 ESPA 4.4.4

#### A.1.1 Functionality

The protocol consists of **blocks** which consist of **records** which consist of **data**.

#### A.1.2 Limitations

##### Protocol Blocks

The original ESPA 4.4.4 specification has 4 different blocks and an additional 5'th block for equipment manufacturer specified functionality. The 5'th block is not used by Ascom and Ericsson dialect, instead two additional blocks 7 and 9 are specified for the dialects.

##### *Request for license*

(Block 7, Ascom and Ericsson dialect): This block is not supported since license handling differs from how it was done in 942SI. The block is NAK:ed if received.

##### *Request for module key number*

(Block 9, Ascom and Ericsson dialect): This block is not supported since license handling differs from how it was done in 942SI. The block is NAK:ed if received.

##### Protocol Records

*Call type: Speech call* (Record 4.2): Speech paging is not supported. This record is handled as a standard paging (Record 4.3)

*Call type: Remote ack of old paging in mobile unit* (Record 4.5, Ascom dialect): This record is NAK:ed since it is not supported by UNITE.

*Call type: Erase of old paging* (Record 4.6, Ascom dialect): If neither "ID" (Record 9) or "Running Number" (Record D) is included in the message, the message is NAK:ed. In 942SI it was ACK:ed but didn't function.

*Call type: Cordless phone, undefined type* (Record 4.7, Ascom dialect): Sent as standard paging (Record 4.3).

*Call type: Cordless phone, internal type* (Record 4.8, Ascom dialect): Sent as standard paging (Record 4.3).

*Call type: Cordless phone, external type* (Record 4.9, Ascom dialect): Sent as standard paging (Record 4.3).

<i>Number of transmissions</i> (Record 5, standard ESPA):	This record is accepted but ignored since it is <b>not supported by UNITE</b> . The parameter can be set in the advanced GUI under "system 900" -> "Default number of transmissions" and is then valid for all messages independent of the record value. Here it is also possible to determine number of transmissions based on the paging priority (advanced).
<i>Mailbox number</i> (Record A, Ericsson dialect):	This record is accepted but ignored since it is <b>not supported by UNITE</b> .
<i>Infopage</i> (Record C, Ascom dialect):	This record is accepted but ignored since it is <b>not supported by UNITE</b> .

### A.1.3 Advanced parameters

<i>Bleep each transmission:</i>	This parameter was available in 942SI. The parameter is not available in USI, instead the parameter can be set in advanced GUI under "system 900" -> "Beep at each Tx".
<i>Flow control XON/XOFF:</i>	Not supported since there are some issues with the control characters. If the block check character becomes any of the two control characters XON or XOFF, the flow control fails, therefore <b>flow control is no longer supported</b> .

## A.2 Limitations in the Ascom Line Protocol

### A.2.1 Functionality

A line protocol message consists of the following records and separators:

<Addr/Message/Beepcode/PagFunc/NoOfTransm/Prio/Infopage>

All characters are writeable by hand using an ordinary terminal program such as hyper terminal etc. Not all records needs to be given, for instance <> is a valid message that delivers default message to default paging address.

### A.2.2 Limitations

The following limitations apply:

<i>PagFunc:</i>	Only call type 3 (plain paging) and 4 (alarm) are supported. All others are handled as plain paging.
<i>NoOfTransm:</i>	The USI does not support no of transmissions but it must be valid if submitted. The parameter can be set in the advanced GUI under "system 900" -> "Default number of transmissions" and is then valid for all messages independent of the record value. Here it is also possible to determine number of transmissions based on the paging priority (advanced).
<i>InfoPage:</i>	The USI does not support Infopage but it must be valid if submitted.

## A.3 TAP Protocol

### A.3.1 Functionality

- `<ESC>PG1<CR>` Default logon string
- First field of the data block is assumed to contain the paging address. The address is treated as a decimal address, valid digits are 0-9. Any leading spaces will be ignored.
- Field(s) after the first field is assumed to contain the paging text. If the datablock is containing more than 2 fields, fields 3,4,5.. will be concatenated to the paging text to be sent. (the separating `<CR>`:s will be treated as a part of the paging text. The paging text is set as 'Body' in the Unite paging. The 'Subject' will be empty.
- There is no restriction on how many blocks that can be sent during one logon session.

### A.3.2 Limitations

The following limitations apply:

*Using <US> or <ETB> as blockterminators:* Not supported.

*Sending <SUB> as controlcharacter:* Not supported.

*Maximum session timeout:* Not implemented, however an inactivity timeout will occur after 8 seconds when waiting for logonstring and 4 seconds when waiting for blockdata after a `<STX>` has been received. After 3 successive timeouts, an automatic disconnect sequence will be initiated. These values can be changed through parameters.

*Timeout between blocks:* There will be no timeout between blocks. After a logon has been received and after each pagingblock, the Serial Interface is put into sleep mode. Three actions can wake it up: A logoff request, a new logon request or a new pagingblock.

*Messages longer than 128 characters:* Will be accepted but truncated.

*Message sequences:* Not used by the Serial Interface.

*Software flow control of the serialport:* Not supported.

*Characters in the paging text below 0x20 (except for carriage return):* Will be converted to something above 0x7F (by adding the 8'th bit).