

Function Description

Shared Phones in Ascom Systems

Contents

1 Introduction	1
1.1 Abbreviations and Glossary	1
2 System Overview	2
2.1 Technical Solution	2
2.2 System Outline	3
2.3 System Requirements	4
3 System Installation	5
3.1 Physical Installation	5
3.2 Parameter Settings	5
4 Operating Instructions	6
4.1 Log On a Shared Phone	6
4.2 Log Off a Shared Phone	6
5 Related Documents	7
6 Document History	8

1 Introduction

The shared phone feature allows a group of users to share handsets in the system and still have their own individual settings, such as volume-, alarm parameters, and local phonebook. The handset has a virtual SIM card stored apart from the handset, and the settings are retrieved to the handset when the user logs on to the system.

This facilitates the management of handsets to a great extent since a user can take any handset and log on to the system. By always having a couple of extra handsets pre-configured for WLAN access, a broken handset can easily be replaced by the user himself.

1.1 Abbreviations and Glossary

ESS	Enhanced System Service: Unite modules that handle centralised number planning, remote connection, system supervision, fault handling, group handling, message routing, centralised logging, activity logging, and user access administration.
IMS2	Integrated Wireless Messaging and Services: Unite module that enables wireless services to and from portable devices and chargers. It also includes the Device Manager.
SIM	Subscriber Identity Module
UNS	User Name Service
Unite CM	Unite Connectivity Manager: a Unite module that enables messaging and alarm handling in a system. It also includes the Device Manager.
WinPDM	Portable Device Manager Windows Version: a software application for initial configuration of the VoWiFi handsets.

2 System Overview

2.1 Technical Solution

When the handset logs on, it must authenticate itself to the IMS2/Unite CM with a password. The password is then stored in the handset until it is switched off or logged out. The IMS2/Unite CM has three authentication alternatives: "Common password", "User server", and "Number as password". A common password, used for all VoWiFi handsets in the system, is recommended for personal phones. For shared phones individual passwords are recommended. When the password is accepted by the IMS2/Unite CM and the handset is found in the Device Manager, it can log on to the VoWiFi System.

The handset itself must be configured as a shared phone. It must also be pre-configured for WLAN access.

Individual passwords can be specified in a User Server. Otherwise, specify in the IMS2/Unite CM that the individual call numbers are to be used.

Unite CM includes a User Server. For IMS2, an ESS can work as a User Server. The IMS2 then checks with the ESS if the password is OK.

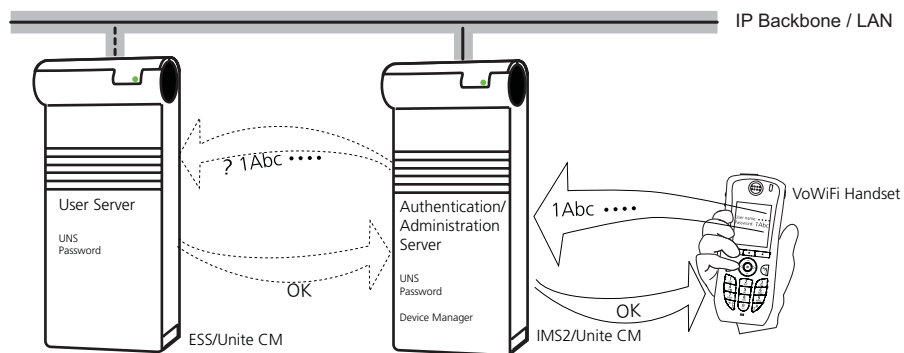

Figure 1. Individual passwords specified in a User Server

When the individual call number is used as password, the IMS2/Unite CM will (if the user name is correct) accept any number, but the handset can only log on to the VoWiFi System if the number is defined in the Device Manager.

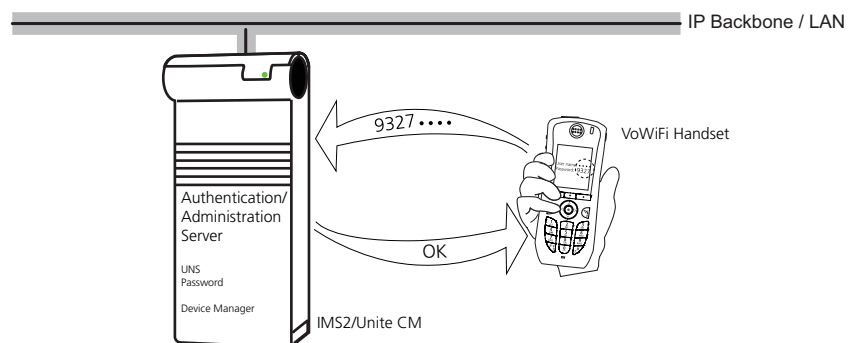

Figure 2. Individual call number used as password

The IMS2/Unite CM is used for handset management and stores all parameters and settings. These parameters and settings are loaded to the handset upon logon. The parameters are synchronised if updated in either the handset or in the IMS2/Unite CM.

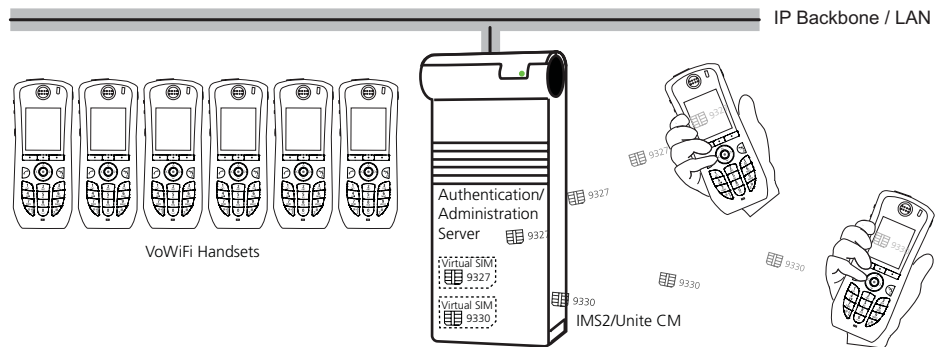

Figure 3. The IMS2/Unite CM stores all handset parameters and settings

2.2 System Outline

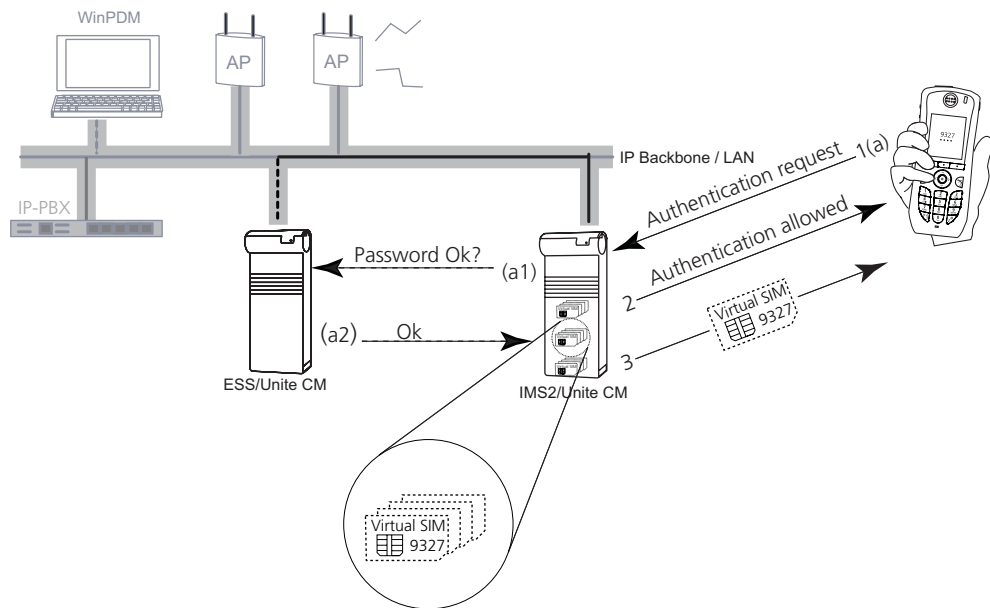

Figure 4. Shared phone logon procedure

When the handset is logged out or powered-up, the logon prompt will be shown in the display. The user needs to enter the password at each logon, and the password is then sent together with an authentication request to the IMS2/Unite CM. If a User Server is involved, the IMS2/Unite CM passes on the request to the User Server, and if the password is registered in the User Server, a confirmation is sent back to the IMS2/Unite CM.

The IMS2/Unite CM accepts the authentication and logs on the handset. When the handset is found in the Device Manager, the IMS2/Unite CM sends the personal parameters, and the handset can be used in the VoWiFi System. The IMS2/Unite CM also synchronizes the parameters between the handset and the Device Manager. If parameters are changed in the handset by a user after logged on, they will be stored in the IMS2/Unite CM.

A "Logon failed" message will, after a timeout, be shown in the display if the handset does not get any response from the Device Manager.

If the number is occupied, that is already logged on, the logon result differs depending on the authentication method used. If common password or number as password is used, the handset will get a "Fail login" message after a timeout. If a User Server is used, the handset will be allowed to log on, and the already logged on handset will be logged out.

When the handset is logged out or switched off, the message list and call list in the handset disappears and will be empty when a new user logs on to the handset.

2.3 System Requirements

- i62 VoWiFi Handset version 2.1.19 or later
- i75 VoWiFi Handset version 1.2.20 or later
- IMS2 version 2.62 or later
- Unite CM version 2.03 or later
- ESS version 2.15 or later (optional)

3 System Installation

3.1 Physical Installation

We assume that all devices in the VoWiFi System are installed, and that the configuration needed is performed in accordance to the information and recommendations in the documentation. This includes third-party documentation together with applicable configuration notes as well as the documents in [5 Related Documents](#) on page 7.

3.2 Parameter Settings

Handset Settings in the IMS2/Unite CM

- The handsets must be configured to be shared, which means that the user profile must have the "Phone mode" parameter set to "Shared". If the user is configured as personal (that is not shared), the handset will become a personal phone upon first log on.
- Each VoWiFi handset must be programmed with the IP address of the IMS2/Unite CM to be able to log on to the IMS2/Unite CM.

How to programme the handset is described in the Installation and Operation Manual IMS2, TD 92586GB. Detailed information on parameters can be found in the Configuration Manual i62 VoWiFi Handset, TD 92675GB, and the Configuration Manual i75 VoWiFi Handset, TD 92431GB.

IMS2/Unite CM

- Either "User server" or "Number as password" needs to be selected as authentication alternative.
If "User server" is selected in IMS2, continue below.
- The operating mode for the User Name Service (UNS) must be set to "forwarding".
- The IP address of the User Server (the ESS which has the users defined) must be set as IP address of forward destination UNS and as User Server IP address.

For detailed description of the configuration in the IMS2/Unite CM, refer to the Installation and Operation Manual IMS2, TD 92586GB, or Installation and Operation Manual Unite CM, TD 92735GB.

ESS/Unite CM

The following is only needed if "User Server" is selected as authentication alternative in the IMS2/Unite CM. For Unite CM these settings have probably already been configured, if it is used for messaging and alarm handling.

- A category for the VoWiFi System needs to be setup, and if an ESS is used the IP address to the IMS2 needs to be specified.
- All shared phone numbers need to be setup in the ESS/Unite CM for the category mentioned above, and if an ESS is used they must be identical to the numbers in the IMS2.
- Users need to be created and attached to the phone numbers.

For detailed description of the configuration in the ESS/Unite CM, refer to the Installation and Operation Manual ESS, TD 92253GB, or Installation and Operation Manual Unite CM, TD 92735GB.

4 Operating Instructions

4.1 Log On a Shared Phone

- 1 Switch the handset on.
- 2 Enter the user name, which in this case is the individual phone number.
- 3 Enter the individual password (can also be the individual phone number). Navigate using the \vee and \wedge on the navigation key.
- 4 Press "Log in".

If the handset does not find the WLAN upon start-up, a "No System" screen is displayed. If the handset does not receive an IP address from the system, a "No Access" screen is displayed.

4.2 Log Off a Shared Phone

- 1 Press and hold the End key .
- 2 A control question "Log off?" is displayed. Confirm by pressing "Yes".

5 Related Documents

System Description Ascom VoWiFi System	TD 92313GB	
Function Description Ascom VoWiFi System	TD 92314GB	
System Planning Ascom VoWiFi System	TD 92408GB	
Configuration Manual i62 VoWiFi Handset	TD 92675GB	
User Manual i62 VoWiFi Handset	TD 92599GB	
Quick Reference Guide i62 VoWiFi Handset	TD 92597GB	
Configuration Manual i75 VoWiFi Handset	TD 92431GB	
User Manual i75 VoWiFi Handset	TD 92319GB	
Quick Reference Guide i75 VoWiFi Handset	TD 92320GB	
Data Sheet i62 VoWiFi Handset	TD 92587GB	
Data Sheet i75 VoWiFi Handset	TD 92318GB	
Data Sheet IMS2	TD 92585GB	
Data Sheet Unite CM	TD 92739GB	
Installation and Operation Manual IMS2	TD 92586GB	
Installation and Operation Manual Unite CM	TD 92735GB	
Installation and Operation Manual ESS	TD 92253GB	

6 Document History

For details in the latest version, see change bars in the document.

Version	Date	Description
A	13 August 2007	First released version.
B	13 December 2010	<ul style="list-style-type: none">• Replaced IMS/IP-WiFi with IMS2 throughout.• Added Unite CM throughout.• Replaced PDM System Version with the Device Manager in the IMS2 throughout.• Added chapter 1.1 Abbreviations and Glossary on page 1.• Clarified that the described usage of common and personal passwords is recommended in chapter 2.1 Technical Solution on page 2.• Added i62 VoWiFi handset and updated the required versions in chapter 2.3 System Requirements on page 4.• Changed the log off procedure in chapter 4.2 Log Off a Shared Phone on page 6.